



PolyGard®2 MSC2

Multi Sensor Controller

Datasheet and User Manual

Version 6.2 2015 eng.

Specifications subject to change without notice.

PolyGard®2 MSC2
 Multi-Sensor-Controller-2
 MSC2-C-53442000
 90-240V AC / 5VA max.
 MW 27/15

www.msr-electronic.de
 Made In Germany



PolyGard®2 MSC2
 Multi-Sensor-Controller-2
 MSC2-C-73442000
 90-240V AC / 15VA max.
 MW 27/15

www.msr-electronic.de
 Made in Germany





PolyGard®2 MSC2 – Data Sheet and User Manual

MSC2- Multi Sensor Controller for toxic and combustible gases, refrigerants and oxygen

Gas measuring, monitoring and warning controller based on state-of-the-art micro-technology for continuous monitoring of the ambient air for toxic and combustible gases, refrigerants or oxygen.

The MSC2 has an input for connecting a digital sensor cartridge (SC2) that transmits the temperature-compensated measurement value in digital form. The controller monitors this value and activates the alarm relay if the set alarm thresholds for pre-alarm and main alert are exceeded. The main alarm is additionally signaled by the integrated buzzer and the three-colour status LED, alarm-fault-operation-service. In case of an internal fault in the sensor cartridge or in the MSC, both equipped with integrated SIL2 compliant self-monitoring, the fault message relay is triggered. The remote monitoring is possible via the integrated RS 485 interface with serial protocol.

For convenient operation the MSC2 is already completely configured and parameterized ex works.

The intended sites within the ambient conditions as specified in the Technical Data are all areas being directly connected to the public low voltage supply, e.g. residential, commercial and industrial ranges as well as small enterprises (according to EN50 082).

The PolyGard® Multi Sensor Controller MSC2 must not be used in potentially explosive atmospheres.

APPLICATION

The MSC2 is designed for leakage detection in **refrigeration** plants.

FEATURES

- Internal function monitoring with integrated hardware watchdog
- Hardware and software according to SIL2 compliant development process
- Easy maintenance and calibration by replacing the sensor cartridge or via comfortable on-site calibration
- Modular technology (plug-in and exchangeable)
- Reverse polarity protected, overload and short-circuit proof
- For one sensor cartridge (SC) at the housing
- Three relays with change-over contact, potential-free max. 250 V AC, 5 A
- Two transistor outputs, 24 V DC, 0.1 A (plus switching)
- Two digital inputs, one of them is occupied for external reset of the horn
- Alarm thresholds alterable via jumper 0.5 / 1.0 vol % or 1.0 / 1.8 vol %
- Different types of housing
- Status LED for alarm, fault, operation and service
- Buzzer
- Operating voltage 230 V AC, power supply with wide range input 90 to 240 V AC
- Operating voltage 24 V DC (option)





PolyGard®2 MSC2 – Data Sheet and User Manual

ORDERING INFORMATION

MSC2- **C** - **5** **3** **4** **4** **2** **0** **0** **0**

WARNING DEVICES
0 Without built-on warning device

DISPLAY
0 Without display

ANALOG INPUT
0 Without analog input

DIGITAL INPUT
2 2x Digital input

OUTPUT SIGNAL – ANALOG / BUS
4 Modbus Interface

VISUAL/ AUDIBLE WARNING DEVICES
4 Buzzer & status-LED (red, yellow, green)

ALARM RELAYS
3 3x Alarm relays

POWER SUPPLY
5 90 – 240 V AC / 24 V DC, 5 VA
7 90 – 240 V AC / 24 V DC, 15 VA

HOUSING
C Housing type C 130 x 130 x 75 (mm)

ELECTRICAL CONNECTION 90-240 V AC / 24 V DC 5 VA (qualified technicians only)

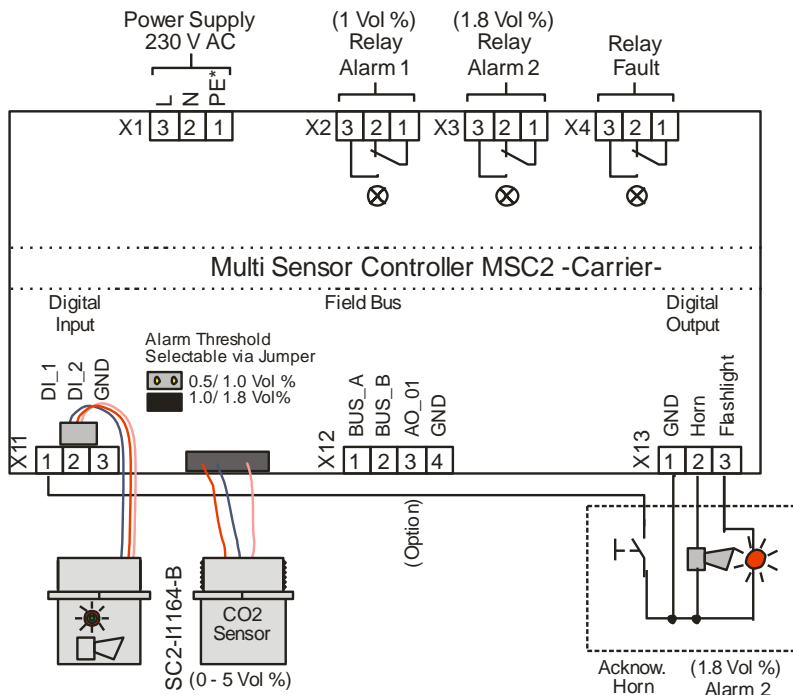

* Connect to ground, if at 230 V supply, a potential difference to ground (floating ground) isn't allowed.





PolyGard®2 MSC2 – Data Sheet and User Manual

ELECTRICAL CONNECTION 90-240 V AC / 24 V DC 15 VA (qualified technicians only)

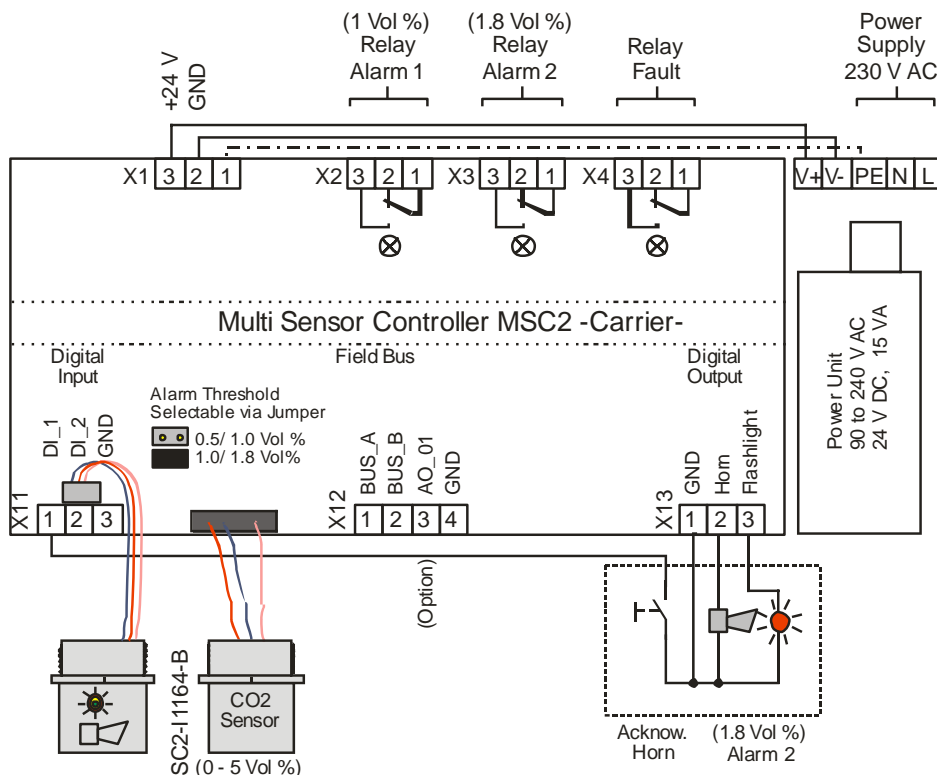

* Connect to ground, if at 230 V supply, a potential difference to ground (floating ground) isn't allowed.

FUNCTION OUTPUTS

Action	Reaction Relay 1 (Alarm 1)	Reaction Relay 2, horn & flashlight (Alarm 2)	Reaction Relay 3 (collective fault message)	Reaction LED
Gas signal < alarm threshold 1	OFF	OFF	OFF	GREEN
Gas signal ≥ alarm threshold 1	ON	OFF	OFF	RED
Gas signal ≥ alarm threshold 2	ON	ON	OFF	RED
Gas signal < (alarm threshold 2 - Hysterese) aber ≥ alarm threshold 1	ON	OFF	OFF	RED
No alarm, no fault	OFF	OFF	OFF	GREEN
No fault, but maintenance due	OFF	OFF	OFF	GREEN flashing
Internal error	OFF	OFF	ON	YELLOW

Note Relay 1 & 2:

Status OFF means: "Alarm off" = Relay coil energized
 Status ON means: "Alarm on" = Relay coil de-energized

Note Relay 3:

Status OFF means: "No fault and MSC2 in normal operation" = Relay coil energized
 Status ON means: "Fault ON or MSC2 without tension" = Relay coil de-energized

Note 1: Status OFF = Relay is configured "Alarm ON = Relay" or the MSC is free from tension.

Note 2: Alarm thresholds can have the same value, therefore the relays and/or the horn and flashlight can be triggered together.





PolyGard®2 MSC2 – Data Sheet and User Manual

Relay Mode

Definition of the relay operation mode. The terms energized / de-energized for this menu item come from the terms open-circuit and closed-circuit principle used for safety circuits. Here, however, not the relay contact circuit is meant (because realized as a changeover contact, optionally available in the two principles), but the activation of the relay coil.

The LEDs attached to the modules show the two states in analogy. (LED off -> relay de-energized)

Relay Function Static / Flash

Definition of the relay function: The function "flashing" represents a connection option for warning devices to improve visibility. If "flashing" is set, this must not be used as a safe output circuit any more.

A combination of relay mode energized with flashing operation makes no sense and is therefore suppressed.

Horn Function (not safe output circuit because resettable)

The horn function is considered active if at least one of the two parameters (time or assignment to digital input) is set. The horn function retains its functionality even for alarms in latching mode.

Special function Recurrence of the horn relay

After an alarm has been triggered, the horn will remain active until it is acknowledged. After acknowledgment of the horn relay/s (clicking a button or via external input) a timer starts. When this time has run out and the alarm is still acting, the relay is set again. This process is repeated endlessly as long as the associated alarm remains active.

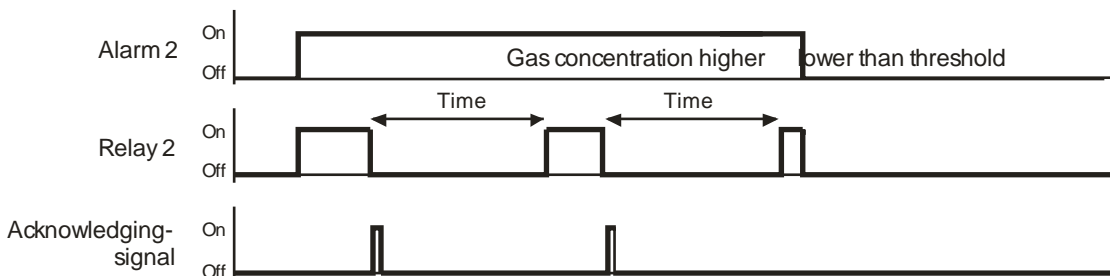



PolyGard®2 MSC2 – Data Sheet and User Manual

MOUNTING / ELECTRICAL CONNECTION

The MSC Gas Controller is fixed to the wall through the four marked mounting points at the back side of the housing. These mounting points are accessible after opening the housing. See figure.

The dimensions XX depend on the type and can be read on the back of the housing, in the housing version of CX, it is 115 mm.

The mounting points are covered by closing the cover at the end of the assembly.

We recommend considering the following when choosing the mounting position:

- Installation height depending on the gas type, for CO₂ near the ground approx. 0.3 m above floor.
- Cables are introduced from above, the sensor head SC downwards.
- Observe possible constructor's instructions.

Mounting Controller:

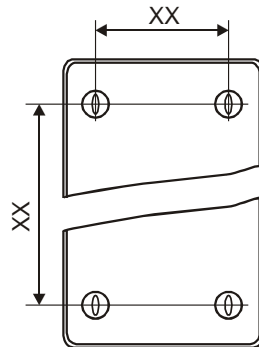

Wiring

The technical requirements and regulations for wiring, electrical security, fire protection, as well as project specific and environmental conditions etc. must be observed when mounting.

We recommend the following cable types ¹

- | | |
|--|-------------------------------|
| ▪ Power supply 230 V at least | NYM-J 3 x 1.5 mm ² |
| ▪ Alarm message 230 V (also possible together with power supply) | NYM-J X x 1.5 mm ² |
| ▪ Signal message, bus connection to DGC06, warning devices 24 V | J-Y(St)Y 2x2 x 0.8 |
| ▪ Possibly connected external analog transmitter | J-Y(St)Y 2x2 x 0.8 |

¹ The recommendation does not consider local conditions such as fire protection etc.

Analog sensors are connected directly to the spring type terminals of the module. The correct polarity must be observed. Digital gas sensors are directly plugged in the connector.

The alarm signals are available as potential-free change-over contacts. If required the voltage supply is available at the terminals L1.

The exact position of the terminals for the sensors and alarm relays is shown in the connection diagram.





PolyGard®2 MSC2 – Data Sheet and User Manual

COMMISSIONING

For sensors that e.g. can be poisoned by silicones like all semiconductor and catalytic bead sensors, it is imperative to remove the protective cap supplied only after all silicones are dry, and then energize the device.

The protective cap has to be used in subsequent cleaning work with water jet or steam, too, in order to protect the sensor.

For fast and comfortable commissioning we recommend proceeding as follows. For digital devices with self-monitoring all internal errors are visible via the LED. All other error sources often have their origins in the field, because it is here where most of the causes for problems in the field bus communication appear.

Optical Check

- Right cable type used.
- Correct mounting height according to definition in Mounting.
- Led status
- Protective cap removed from the sensor.

Run-in period

In order to obtain an optimum fresh air setting, it is necessary to run the unit continuously at least for 48 hours without shutdown under unpolluted ambient air conditions.

Selection Gas Type with Unit

The selection of the desired and connected gas sensor type is made by pre-set values.

If other gas sensor types are connected, you have to adjust them with the configuration tool, because otherwise the device will respond with an error message.

Connection possible as digital sensor cartridge SC2.

The selection contains all necessary information for the controller and is also used for comparing the real, digital data with the settings.

This feature increases the user and operating security.

There is an entry available per gas type for each unit; at the moment there are 100 selection options.





PolyGard®2 MSC2 – Data Sheet and User Manual

MSR-Type	Gas Type	Formula	Range	unit
1164	Carbon dioxide	CO2	0-2000	ppm
1164	Carbon dioxide	CO2	0-5	% Vol
3480	Propane	C3H8	0-100	% LEL
I480	IR-Propane	C3H8	0-100	% LEL
I480	IR-Propane	C3H8	0-100	% Vol
2066	R11	R11		ppm
2059	R12	R12	20-2000	ppm
2070	R22	R22	20-300	ppm
2061	R23	R23	20-2000	ppm
2060	R32	R32		ppm
2064	R123	R123	20-300	ppm
2077	R134a	R134a	20-300	ppm
2063	R1234yf	R1234yf		ppm
2065	R125	R125		ppm
2071	R401a	R401a	20-2000	ppm
2072	R401b	R401b	20-2000	ppm
2073	R402a	R402a	20-2000	ppm
2074	R402b	R402b	20-2000	ppm
2082	R403a	R403a		ppm
2078	R404a	R404a	20-300	ppm
2083	R407a	R407a		ppm
2080	R407c	R407c	20-300	ppm
2075	R408a	R408a	20-2000	ppm
2076	R409a	R409a	20-2000	ppm
2068	R410a	R410a	20-300	ppm
2067	R411a	R411a	20-300	ppm
2079	R416a	R416a	20-300	ppm
2084	R417a	R417a	20-2000	ppm
2081	R422d	R422d	20-300	ppm
2062	R434a	R434a	20-300	ppm
2069	R507	R507	20-2000	ppm





PolyGard®2 MSC2 – Data Sheet and User Manual

CONFIGURATION AND PARAMETER CARDS

Commission:		Order number:	
Customer:		Service technician:	
Commissioning - company:		Date	

Configuration Card System Parameters

Serial No.	Date of Production	Mainten. interval	Mainten. Password	AV Overlay		AV Time	Power On Time	Error Time	CFM dupl.
				V-time	ppm				
Note	Note down	1900	****						0
				0	0	90	30	30	

Analog Output 1		
Outp.	source	Oper.
Signal		Mode
100%	CV	MAX

Relay Multiplication									
1		2		3		4		5	
In	Out	In	Out	In	Out	In	Out	In	Out
0	0	0	0	0	0	0	0	0	0

Configuration Card Alarm Relays / Signal Outputs

Relay No.	active inactive	Mode	Stat. Flash	Reset	Horn		Extern. On	Extern. Off	Delay at ON	Delay at OFF	Fault ORed	Maint. ORed
				Time	Recur.	DI	DI	DI	sec	sec		
Default	inactive	de-en	Stat.	0	no	0	0	0	0	0	OFF	OFF
R 01	active	energ.										
R 02	active	energ.										
R 03	active	de-en										
Horn	active	de-en										
LED red	active	de-en	flash			1						





PolyGard®2 MSC2 – Data Sheet and User Manual

Configuration Card SC2 devices (digital measuring points)

DP Nr.	MP Status	Locked	Gas type		Range	Alarm Thresholds				Hyst	CV- Delay Alarm (Sec)	at ON	at OFF	CV-AV	Assignment Latching				Assignment Fault <>Alarm				Assignment Alarm <> Alarm Relay				Ao1
			Gas	unit		A1	A2	A3	A4						A1	A2	A3	A4	A1	A2	A3	A4	A1	A2	A3	A4	
01	active	n	CO2	%Vol	5	0.5	1	1	1	0.2	0	0	CV	0	0	0	0				1	R1	R2	R3	R4		
02	inactive	n																									
03	inactive	n																									
Change of values after replugging the jumper (closed)																											
01	active	n	CO2	%Vol	5	1	1.8	1	1	0.2	0	0	IW	0	0	0	0				1	R1	R2	R3	R4		
02	inactive	n																									
03	inactive	n																									

Configuration Card MC2 (analog measuring points)

AP Nr.	MP Status	Locked	Gas type		Range	Alarm Thresholds				Hyst	AV- Delay Alarm (Sec)	at ON	at OFF	CV-AV	Assignment Latching				Assignment Fault <>Alarm				Assignment Alarm <> Alarm Relay				Ao1
			Gas	unit		A1	A2	A3	A4						A1	A2	A3	A4	A1	A2	A3	A4	A1	A2	A3	A4	
	inactive	No	CO2	ppm	300	30	60	120	120	15	0	0	AV	0	0	0	0				1	R1	R2	R3	R4		
01	inactive																										
02	inactive																										
03	inactive																										



PolyGard®2 MSC2 – Data Sheet and User Manual

FUNCTIONAL TEST (FOR INITIAL OPERATION AND MAINTENANCE)

The functional test should be carried out during each service, but at least once a year.

ZERO-POINT TEST WITH FRESH OUTDOOR AIR

Due to the employed optical measurement principle, there won't be any deterioration caused by ageing or chemical processes in the sensor. However, a zero offset may occur.

Using the Service Tool STL 06 you can read it out and document it in form of a measured value.

TRIP TEST WITH REFERENCE GAS

The sensor is gassed with reference gas CO₂, concentration, 2-3 % vol, (for this you need a gas bottle with pressure regulator and a calibration adapter).

In doing so, the set alarm thresholds are exceeded, and all output functions are activated. It is necessary to check if the connected output functions are working correctly (e.g. the horn sounds, the fan switches on, devices shut down). By pressing the push-button on the horn, the horn acknowledgment must be checked. After removal of the reference gas, all outputs must automatically return to its initial position.

Other than the simple functional testing, it is also possible to perform a functional test by means of calibration. For further information, please refer to the User Manual.

CALIBRATION

New Sensor Cartridges SC2 are always delivered factory-calibrated by MSR-E. This is documented by the calibration label indicating date and calibration gas. A repeated calibration is not necessary during commissioning if the device is still in its original packaging (air-tight protection by the red protective cap) and the calibration doesn't date back more than 12 months for CO₂ sensors and 3 months for all other gases.

Due to high operational stability of the sensor, and the intrinsically safe design of the gas detector, the gas detector doesn't need an annual calibration.

After an operating period of 5 years, only the sensor cartridge must be recalibrated & adjusted by the manufacturer or replaced. If this time has been exceeded, the device answers automatically with the green LED flashing. This replacement of the sensor cartridge can be repeated without limitation, as long as there isn't a malfunction (fault X4). The evaluation unit must not be exchanged.

After exchange of the sensor, the LED shows the correct operation again (green).





PolyGard®2 MSC2 – Data Sheet and User Manual

For the calibration of the sensor cartridge, you need a PC tool or the MSC-06-STL Service Tool. There is an automatic routine in the calibration menu of the Service Tool STL.

As long as the calibration menu is open and the sensor is gassed with test gas, the alarm release is blocked.

Prior to calibration the sensor must be connected continuously to the power supply for stabilization for a running-in period.

This running-in period of some sensors can be taken from the following table:

	Sensor/Gas type	T _{on}
01	CO ₂	2 days fresh air
02	Combustible gases	1 h
05	NH ₃	18 h
07	Freons	8 days

Project protection

To prevent access to the sensitive calibration data by third parties, every customer receives his own internal project key. All projects of the customer are delivered with this key. The key is also stored in each MSC-06-STL Tool that the respective customer buys.

If the keys do not match, the following message appears

NO ACCESS AUTHORIZATION

The calibration is documented in the User Manual of the Service Tool.

SPECIFICATIONS MULTI SENSOR CONTROLLER

Electrical

Power supply	90 - 240 V AC, 24 V DC reverse-polarity protected (option)
Power consumption (24 V DC)	Max. 60 mA (1.5 VA)
- per sensor (SC or MC)	Max. 85 mA (2.1 VA)
- horn / warning light	Max. 40 mA (1.0 VA)
Alarm relays (3)	250 V AC, 5 A, potential-free, change-over contact (SPDT)
Transistor outputs (2)	24 V DC / 0.1 A, (switching to plus)
Digital inputs (2)	Potential-free contact

Ambient conditions

Temperature range	-25 °C to +50 °C (-13 °F to +122 °F)
Humidity range	15 - 95 % RH not-condensing
Storage temperature	5 °C to 30 °C (41 °F to 86 °F)
Storage time	12 months in original packaging

Physical

Housing type C	Polycarbonate
Combustion	UL 94 V2
Housing colour	RAL 7032 (light grey)
Dimension housing (W x H x D)	130 x 130 x 75 mm (5.12 x 5.12 x 2.95 in.)
Weight	ca. 0.6 kg (1.32 lb.)
Protection class	IP 65



MSR-Electronic GmbH :: Würdinger Str. 27 + 27A :: 94060 Pocking

Specifications subject to change without notice
PolyGard® is a registered trademark of MSR-Electronic GmbH



PolyGard®2 MSC2 – Data Sheet and User Manual

Installation	Wall mounting
Cable entry	Standard 3 x M20/25
Wire connection:	Local bus (SC)
	Digital input, analog output
	Power supply, relays
	3-pin connector
	Screw-type terminals, min. 0.25 mm ² , max. 1.3 mm ²
	Screw-type terminals, min. 0.25 mm ² , max. 2.5 mm ²
Warning buzzer	
Acoustic pressure	> 90 dB (A)
Frequency	2300 Hz
Protection class	IP 65
Status-LED	
Colour / mode	Red / yellow / green (warning-fault-operation-service)
Protection class	IP 65
Scope included	
3x M20x1.5	Cable gland for MSC2
1x M16x1.5	Cable gland for WH/BL24-Tast

SPECIFICATIONS SENSOR CARTRIDGE

Sensor element

Gas type	Carbon dioxide CO ₂
Sensor element	Infrared (NDIR)
Measuring range	5 vol. %
Measuring interval	2 sec.
Accuracy	< 10 % of range
Response time	t ₉₀ < 120 s
Sensor life time	15 years for normal ambient conditions
Calibration interval (recommendation)	5 years
Temperature range	-35 to + 40 °C
Humidity range	0 - 90 % RH not condensing
Pressure range	Atmospheric ± 30 % (influence + 1.6 % on measured value per kPa)
Storage temperature range	+ 5 to + 30 °C (41 to 86 °F)
Storage time	12 months in their original packaging

Physical

Housing M25	Polycarbonate
Combustion	UL 94 V2
Housing colour	RAL 7032 (light grey)
Dimensions: M25 housing	(D x H) 24 x 22 mm (0.94 x 0.87 in.)
Weight	ca. 30 g (0.07 lb)
Protection class	IP 65
Mounting	Screw mounting
Connection type	3-pin connector
Cable length	110 mm (4.33 in.)

Directives

EMC directives 2004/108/EC
CE
Conformity to:
EN 50271
EN 61010-1:2010
ANSI/UL 61010-1
CAN/CSA-C22.2 No. 61010-1E
EN 378-1 (refrigeration plants)

Warranty

1 year on material



MSR-Electronic GmbH :: Würdinger Str. 27 + 27A :: 94060 Pocking

Specifications subject to change without notice
PolyGard® is a registered trademark of MSR-Electronic GmbH



PolyGard®2 MSC2 – Data Sheet and User Manual

NOTES AND GENERAL INFORMATION

It is important to read this user manual carefully in order to understand the information and instructions. The PolyGard®2 MSC system may only be used for applications in accordance to the intended use. The appropriate operating and maintenance instructions and recommendations must be followed.

Due to permanent product developments, MSR-E reserves the right to change specifications without notice. The information contained herein is based on data considered to be accurate. However, no guarantee or warranty is expressed or implied concerning the accuracy of these data.

Intended Product Application

The PolyGard®2 MSC system is designed and manufactured for controlling, for saving energy and keeping OSHA air quality in commercial buildings and manufacturing plants.

Installer's Responsibilities

It is the installer's responsibility to ensure that all PolyGard®2 MSC systems are installed in compliance with all national and local regulations and OSHA requirements. All installation shall be executed only by technicians familiar with proper installation techniques and with codes, standards and proper safety procedures for control installations and the latest edition of the National Electrical Code (ANSI/NFPA70).

The equipotential bonding required (also e.g. secondary potential to earth) or grounding measures must be carried out in accordance with the respective project requirements. It is important to ensure that no ground loops are formed to avoid unwanted interference in the electronic measuring equipment.

It is also essential to follow strictly all instructions as provided in the user manual.

Maintenance

We recommend checking the PolyGard®2 MSC system regularly. Due to regular maintenance differences in efficiency can easily be corrected. Re-calibration and replacement of parts can be realised on site by a qualified technician with the appropriate tools. A separate documentation is available for this. Alternatively the removable Gas Controller can be returned to MSR-Electronic GmbH for services.

Limited Warranty

MSR-Electronic GmbH warrants the PolyGard®2 MGC system against defects in material or workmanship for a period of one (1) year beginning from the date of shipment. Should any evidence of defects in material or workmanship occur during the warranty period, MSR will repair or replace the product at their own discretion, without charge. This warranty does not apply to units that have been altered, had attempted repair, or been subjected to abuse, accidental or otherwise. The above warranty is in lieu of all other explicit warranties, obligations or liabilities.

This warranty extends only to the PolyGard®2 MSC system. MSR-Electronic GmbH shall not be liable for any incidental or consequential damages arising out of or related to the use of the PolyGard®2 MSC systems.



MSR-Electronic GmbH :: Würdinger Str. 27 + 27A :: 94060 Pocking

Specifications subject to change without notice
PolyGard® is a registered trademark of MSR-Electronic GmbH



EG - Konformitätserklärung EC - Declaration of Conformity

Wir erklären in alleiniger Verantwortung, dass die bezeichneten Produkte mit den folgenden Normen und Richtlinien übereinstimmen.

We declare under our sole responsibility that the products to which this declaration relates are in conformity with the following standards and directive.

Dokument-Nr. / Document-No. CE_MSC2 & MGC2_0615
Hersteller / Manufacturer: MSR - Electronic - GmbH
 Würdinger Str. 27
 D-94060 Pocking
Produktbezeichnung / Name: PolyGard®2 Multi Sensor Controller Series MSC2 & MGC2
Richtlinie / Directive: 2004 / 108 / EC
 Elektromagnetische Verträglichkeit. / Electromagnetic compatibility
 2006 / 95 / EC

Niederspannungsrichtlinie / Low voltage Directive

Norm / Standard: EN 61010-1-2010+Cor. 2011
 Sicherheitsbestimmungen für elektrische Mess-, Steuer-, Regel-, und Laborgeräte.

Norm / Standard: EN 50 271 (IEC-61508)
 Elektrische Geräte für die Detektion und Messung von brennbaren Gasen, giftigen Gasen oder Sauerstoff - Anforderungen und Prüfungen für Warngeräte, die Software und/oder Digitaltechnik nutzen; Deutsche Fassung EN50271:2010

Für die funktionale Sicherheit entspricht der komplette Entwicklungsprozess für Hard- und Software Sicherheitslevel SIL2, Low Demand.

Electrical apparatus for the detection and measurement of combustible gases, toxic gases or oxygen - Requirements and tests for apparatus using software and/or digital technologies; German version EN50271:2010

Full Development process for hard- and software is designed according safety requirement SIL2 –low demand

Aussteller/ Issued by: MSR - Electronic - GmbH
Datum / Date: Pocking, 07.07.15

Rechtsverbindliche Unterschrift/ binding signature:

.....
 Dipl.-Ing. Wolfgang Schmitt

Diese Erklärung bescheinigt die Übereinstimmung mit den genannten Richtlinien, beinhaltet jedoch keine Zusicherung von Eigenschaften. Die Sicherheitshinweise der mitgelieferten Produktdokumentation sind zu beachten.

This declaration certifies the conformity to the mentioned directives. It does not confirm any attributes. The security hints of the specific instruction manuals have to be followed

